

細長型橫向銑頭

Angle Head-Ultra Slim

- 小型化設計、加長型下座，適用於深槽與深孔之內面加工。
- 自動刀庫換刀加工，量化生產必備工具。
- 環抱型定位塊設計，可 360 度旋轉調整加工角度，並加強鎖固力道及加工角度精確性。

- Compact and longer body design is suitable for machining the deep-hole and deep-slot.
- Can be automatic tool changed. Increases productivity.
- Enclosed Positioning Pin: Cutting Direction can be adjusted from 0~360 degrees. It allows higher clamping torque and cutting direction could remain during the machining.

內孔偏擺	0.002mm
材質	合金鋼
轉速	最高 6000 RPM
扭力	最大 6 Nm
鑽孔	最大 6 mm
攻牙	最大 M4
齒輪比	1 : 1
適用主軸	BT, SK(ISO), CAT
標準配件	T 型扳手
出力軸轉向	反轉

Run-out	0.002mm
Material	Alloy Steel
R.P.M.	Max. 6000 RPM
Torque	Max. 6 Nm
Drilling	Max. 6 mm
Tapping	Max. M4
Gear Ratio	1 : 1
Spindle Type	BT, SK(ISO), CAT
Standard Accessory	T Handle Hex. Wrench
Output Rotation	Reverse to Input Rotation

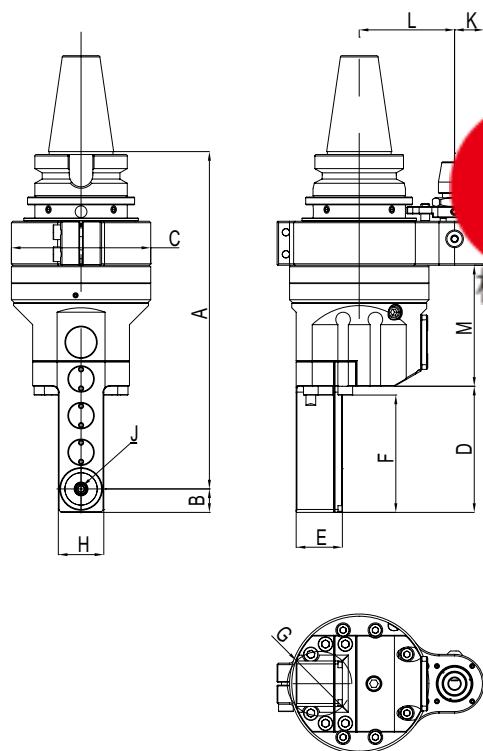

思誠資源
WWW.SCZY.COM
机床附件 供应商



Unit : mm

Model No.	A	B	C	D	E	F	G	H	J	K	L	M	N.W. (KG)
AHL-BT40-C4.65	230	16	95	86	31.5	80	44	31	2~6 (ADC6)	20	65	82.5	6.6
AHL-BT50-C4.80	237	16	95	86	31.5	80	44	31	2~6 (ADC6)	20	80	82.5	9
AHL-BT50-C4.110	237	16	95	86	31.5	80	44	31	2~6 (ADC6)	20	110	82.5	9
AHL-SK40-C4.65	230	16	95	86	31.5	80	44	31	2~6 (ADC6)	20	65	82.5	6.6
AHL-SK50-C4.80	237	16	95	86	31.5	80	44	31	2~6 (ADC6)	20	80	82.5	9
AHL-SK50-C4.110	237	16	95	86	31.5	80	44	31	2~6 (ADC6)	20	110	82.5	9
AHL-CAT40-C4.65	230	16	95	86	31.5	80	44	31	2~6 (ADC6)	20	65	82.5	6.6
AHL-CAT50-C4.80	237	16	95	86	31.5	80	44	31	2~6 (ADC6)	20	80	82.5	9
AHL-CAT50-C4.110	237	16	95	86	31.5	80	44	31	2~6 (ADC6)	20	110	82.5	9

※ 此橫銑頭須採用我司特製 ADC 筒夾，詳細規格請見 P31。

※ This Angle Head requires the adoption of special ADC collet offered by Hold Well. The specification is listed on Page 31.